



## XHBN.HW-D-1091 Joint Systems

[Page Bottom](#)

### Design/System/Construction/Assembly Usage Disclaimer

- Authorities Having Jurisdiction should be consulted in all cases as to the particular requirements covering the installation and use of UL Listed or Classified products, equipment, system, devices, and materials.
- Authorities Having Jurisdiction should be consulted before construction.
- Fire resistance assemblies and products are developed by the design submitter and have been investigated by UL for compliance with applicable requirements. The published information cannot always address every construction nuance encountered in the field.
- When field issues arise, it is recommended the first contact for assistance be the technical service staff provided by the product manufacturer noted for the design. Users of fire resistance assemblies are advised to consult the general Guide Information for each product category and each group of assemblies. The Guide Information includes specifics concerning alternate materials and alternate methods of construction.
- Only products which bear UL's Mark are considered as Classified, Listed, or Recognized.

## Joint Systems

[See General Information for Joint Systems](#)

### System No. HW-D-1091

June 08, 2010

Assembly Rating — 2 Hr

Nominal Joint Width — 2-1/4 to 6 in.

Class II & III Movement Capabilities — 25% Compression or Extension

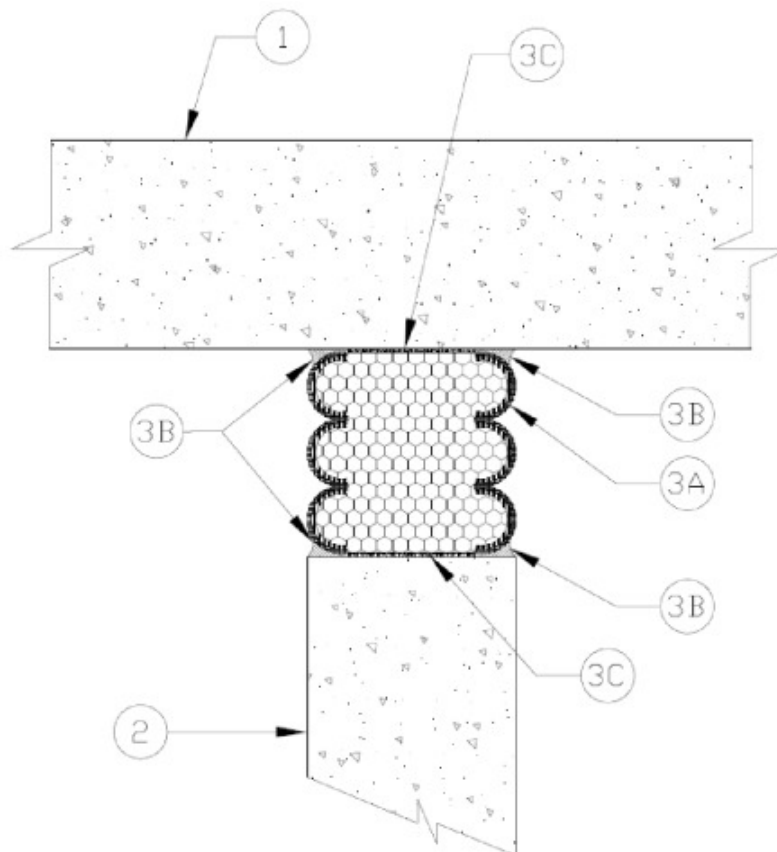

1. **Floor Assembly** — Min 4-1/2 in. (114 mm) thick reinforced normal weight 150 pcf. (2400 kg/m<sup>3</sup>), structural concrete.

2. **Wall Assembly** — Min 4 in. (100 mm) thick reinforced lightweight or normal weight (100-150 pcf, or 1600-2400 kg/cu meter), structural concrete. Wall may also be constructed of any UL Classified **Concrete Blocks\***.

See **Concrete Blocks** (CAZT) category in the Fire Resistance Directory for names of manufacturers.

3. **Joint System** — **Nominal width of joint is 2-1/4 to 6 in. (55 to 150 mm). The joint system is designed to accommodate a max 25 percent compression or extension from its installed width.** The joint system shall consist of the following:

A. **Forming Material** — Compressed, fire-retardant impregnated, 3 3/4 in. (95 mm) deep foam coated on each side with intumescent and polyurethane sealant. Foam is installed in joint opening as a permanent form.

**EMSEAL L L C** — SSW2 Mechanical joint system.

B. **Sealant Band** — (Optional) — Watertight 3/4 in. (19 mm) deep polyurethane sealant band and corner bead supplied by joint system manufacturer, and installed in accordance with installation instruction.

C. **Epoxy adhesive** — Consists of two parts; part A (base), and part B (hardener). The epoxy is supplied by joint system manufacturer, and installed in accordance with installation instructions.

Last Updated on 2010-06-08

[Questions?](#)

[Print this page](#)

[Notice of Disclaimer](#)

[Page Top](#)

[Copyright © 2010 Underwriters Laboratories Inc.®](#)

The appearance of a company's name or product in this database does not in itself assure that products so identified have been manufactured under UL's Follow-Up Service. Only those products bearing the UL Mark should be considered to be Listed and covered under UL's Follow-Up Service. Always look for the Mark on the product.

UL permits the reproduction of the material contained in the Online Certification Directory subject to the following conditions: 1. The Guide Information, Designs and/or Listings (files) must be presented in their entirety and in a non-misleading manner, without any manipulation of the data (or drawings). 2. The statement "Reprinted from the Online Certifications Directory with permission from Underwriters Laboratories Inc." must appear adjacent to the extracted material. In addition, the reprinted material must include a copyright notice in the following format: "Copyright © 2010 Underwriters Laboratories Inc.®"

An independent organization working for a safer world with integrity, precision and knowledge.

